



2250 County Road 319
Rifle, CO 81650
970 945 7777
info@offroaddesign.com

Heavy-Duty Front Main Eye Hanger

<u>Quantity in kit</u>	<input checked="" type="checkbox"/>	<u>Part</u>
2		Front Main Eye Hanger
16		7/16" x 1-1/4" Grade 8 bolts (12 qty for GU27030)
16		7/16" Top lock nuts
16		7/16" Washers

Be careful! This kit requires you to secure the vehicle by the frame, drop the front end of the front springs and at least drill and grind on the frame. Make sure the truck is secure and be sure that you are aware of what is inside the frame rails.

Once the vehicle is secure and the front springs are out of the way:

- 1: Remove the old upper main eye hangers by first removing the body mount bolt (you may need to support the core support with a jack). Then remove the cross bolts for the main eye and drop the leaf springs out before removing the original rivets. An air chisel is our favorite method but a grinder, drill, hammer and chisel, or torch are all other options.
2. Unbolt the rear of the bumper braces and loosen the front carriage bolt, swing them out of the way for drill access while installing. Total removal of the factory front bumper is not necessary.
- 3: Check the fit of the new main eye hangers in the frame. You will need to enlarge the frame holes for the larger 7/16" bolts. Chances are the existing bolt holes are not in exactly the same location as the new brackets since the frame stamping wasn't super precise, but they should be close. We recommend drilling the forward hole on the bottom of the frame first, and then using the 7/16" bolt to locate the new main eye hanger before drilling the rest of the holes, using the bracket as a drill guide. In some brackets, for example in our 2WD to 4x4 brackets, additional mounting holes may be need to be drilled.
- 4: Torque the mounting bolts that go through the frame to 50 ft lbs, the proper way to torque a nut/bolt is to put the torque wrench on the nut rather than the bolt.
- 5: Re-install your bumper braces, body mount, and leaf springs (torque cross-bolts to 75 lb ft).

GU27030
1967-72 4x4

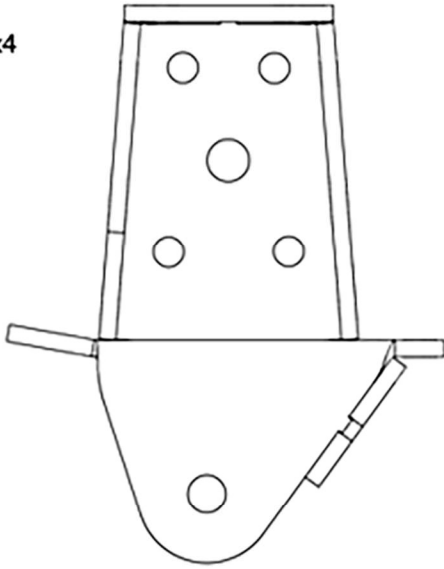

GU37032
1973-80 4x4

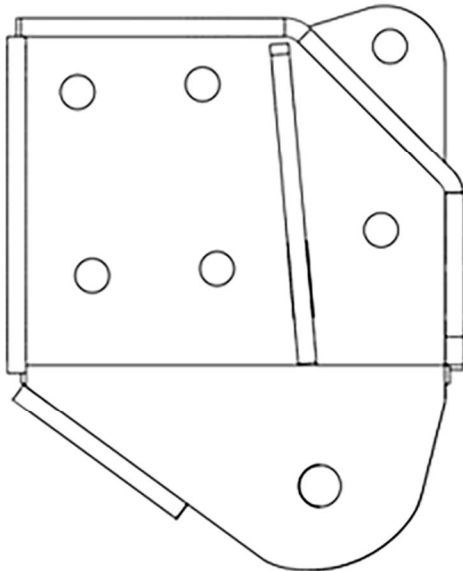

GU37033
1973-80 2WD to
4x4 Conversion

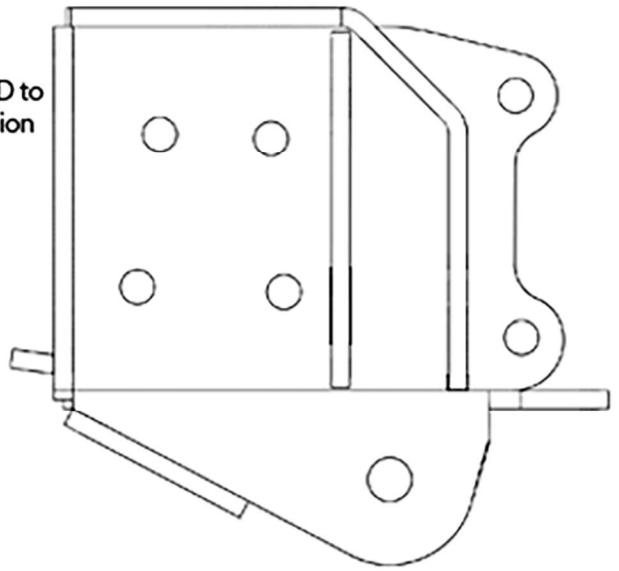

GU37030
1981-87 (91) 4X4

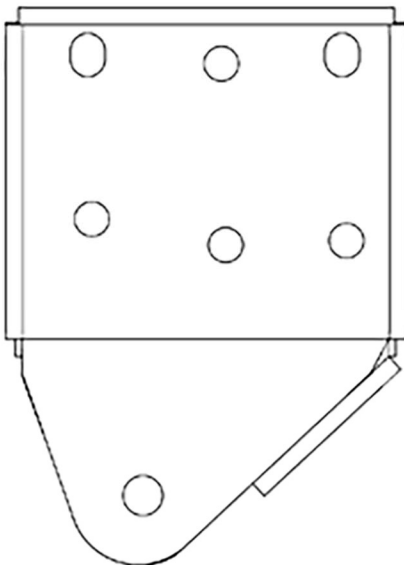

GU37031
1981-87 (91)
2WD to 4X4
Conversion

